

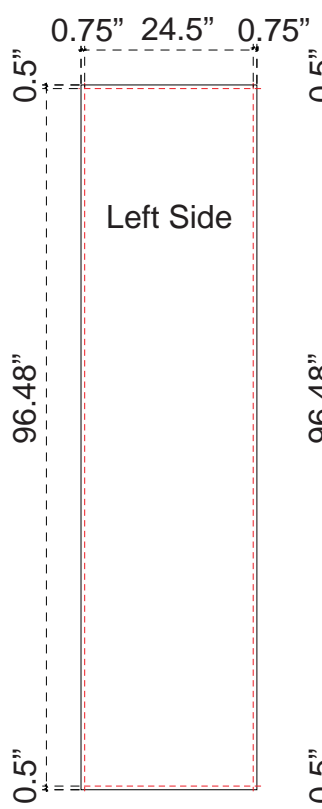

Hybrid Displays  
P20 Backwall Graphic Dims

Product Name: Perfect 20
Process: Select
Material: Poly Knit 9
Effective Date: 03/20/2012



Live Area:  
23"w x 95.48"h  
with 0.75" bleed TOP  
0.5" bleed SIDES  
Finished Size:  
24.5"w x 96.48"h

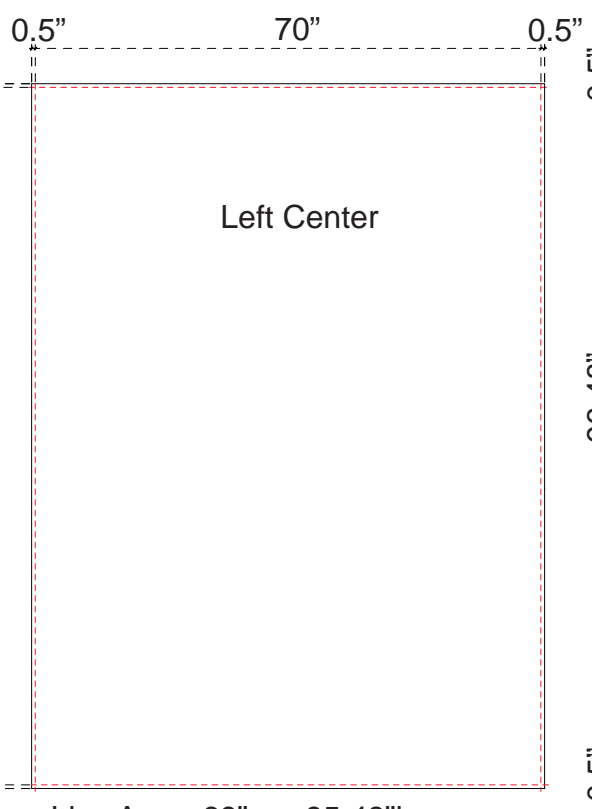

Live Area: 69"w x 95.48"h  
with 0.5" bleed around perimeter  
Finished Size: 70"w x 96.48"h

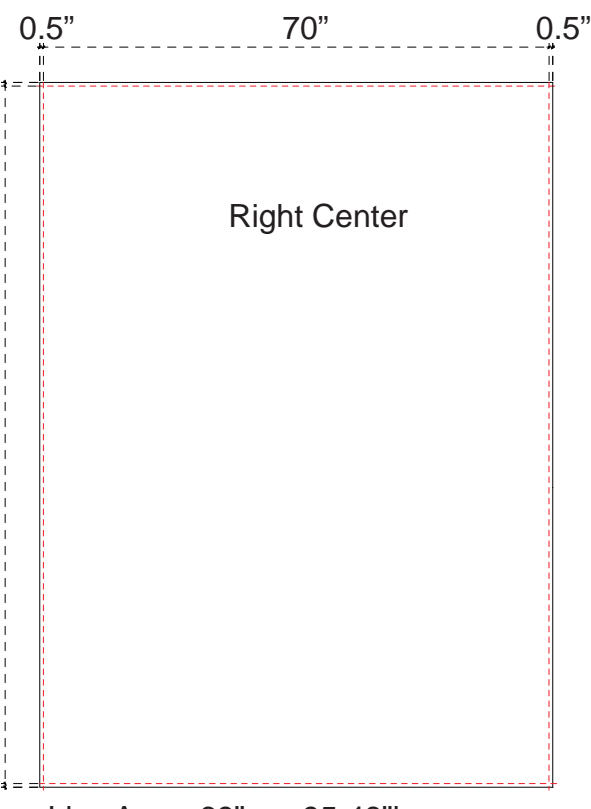

Live Area: 69"w x 95.48"h  
with 0.5" bleed around perimeter  
Finished Size: 70"w x 96.48"h

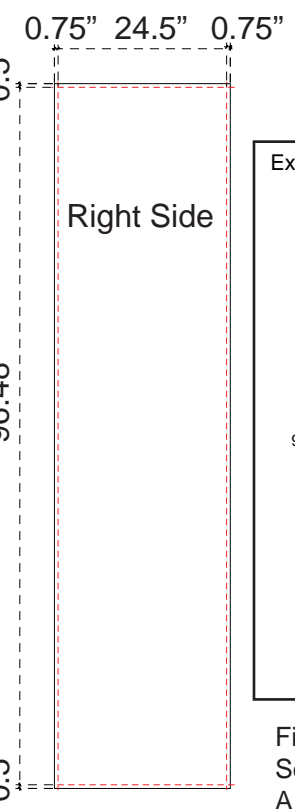

Live Area:  
23"w x 95.48"h  
with 0.75" bleed TOP  
0.5" bleed SIDES  
Finished Size:  
24.5"w x 96.48"h

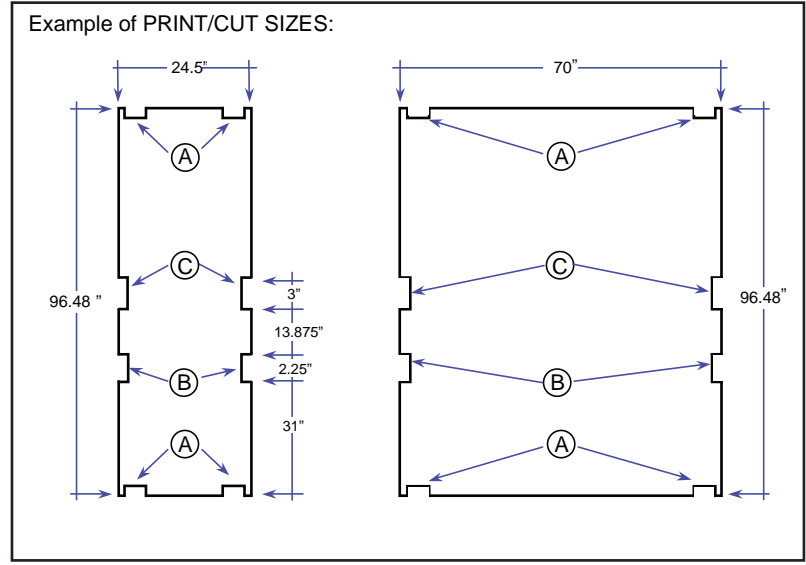

- Finishing  
Sew 1/2" Velcro to front perimeter of graphic
- A - The 4 corner notches are cut 1/2" in from the edge and 1/4"h x 3/4"w
  - B - For the side notches - measure 31" up from the bottom of the graphic. Notch is 2.25"h x 0.25"w.
  - C - Measure up an additional 13.875" from the top edge of the first notch. Notch is 3"h x 0.25"w

NOTE: Graphic files must be @ 150 dpi Finished Size.  
DO NOT send Flattened Files. Production can not manipulate the content, proportion or color of these files.

NOTE: These dimensions are for graphic layout purposes.  
Graphic needs to be cut and test fitted to P10 frame.

Product Name: Perfect 20
Process: Select
Material: Poly Knit 9
Effective Date: 03/20/2012

*A small portion of your graphic(s) may be hidden by P20 accessories, such as Monitors and Cubby Counters. Please use these diagrams to position your graphics correctly.*



Hybrid Displays  
P20 Backwall Graphic Dims with Accessories

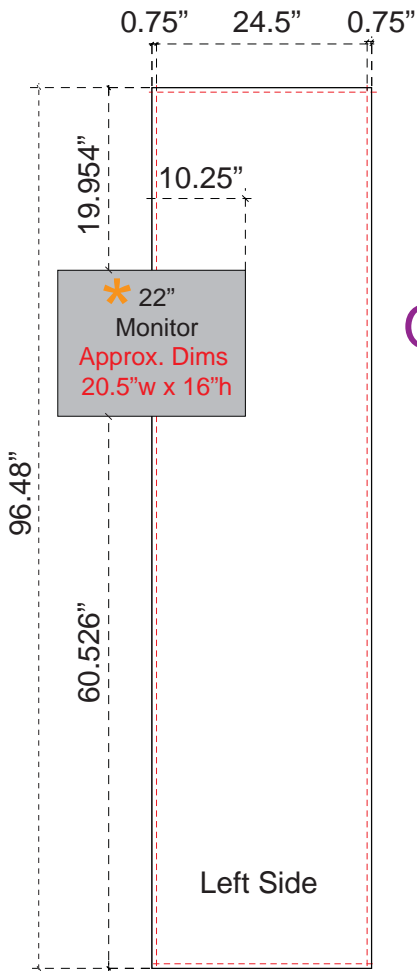

OR

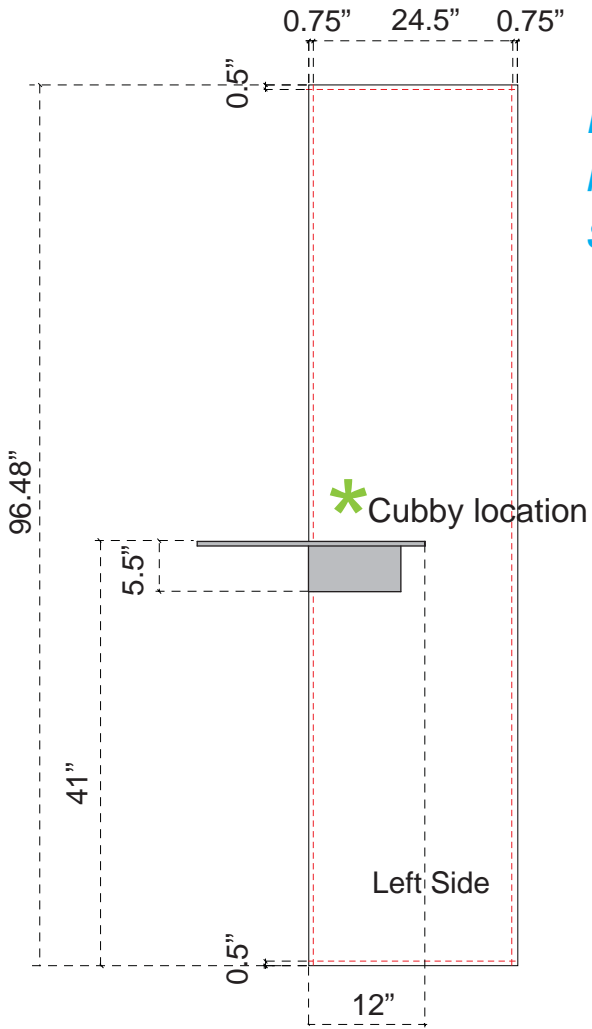
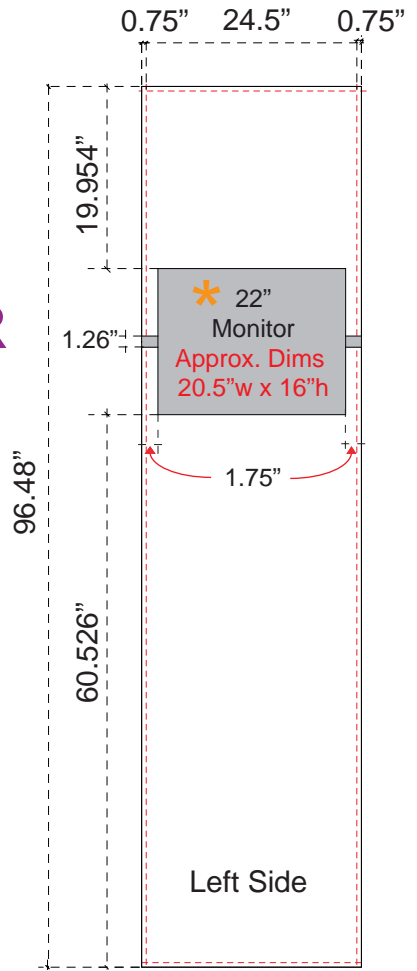

*Note: Monitor and Cubby locations will be reversed when used on the right side of the P20.*

\* Note: When adding Monitors to the P20 unit, a portion of the graphic will be covered. Please design graphic layout according to desired Monitor Location.

\* Note: When adding a Cubby to the P20 unit, a portion of the graphic will be covered.

See Header Graphic Dims for header locations.

See Header Graphic Dims for header locations.



Hybrid Displays  
P20 Backwall Header Graphic Dims

NOTE: Graphic files must be @ 150 dpi Finished Size.

Product Name: Perfect 20
Process: Print on
Material: 1/4" Sintra
Effective Date: 03/20/2012

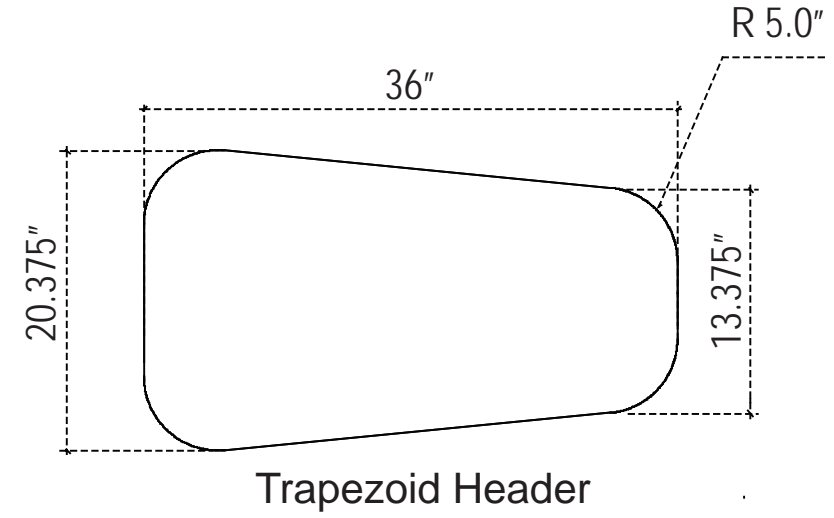
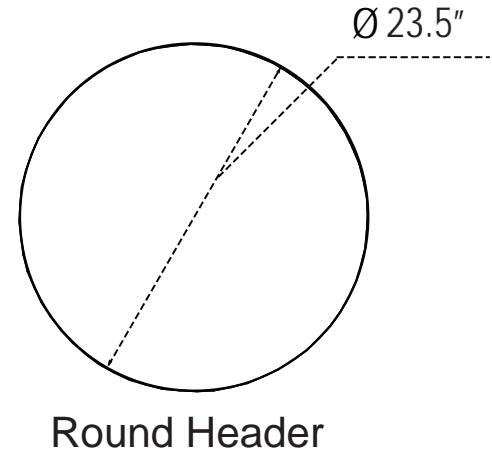
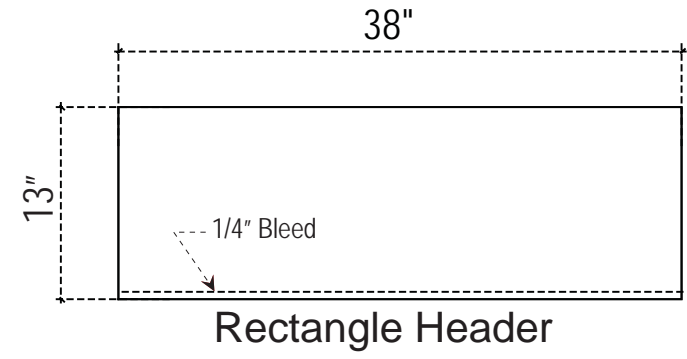

A small portion of your graphic(s) may be hidden by P20 accessories, such as Headers. Please use these diagrams to position your graphics correctly.

Examples of P20 Backwall Left or Right Side Graphic Dims with Headers

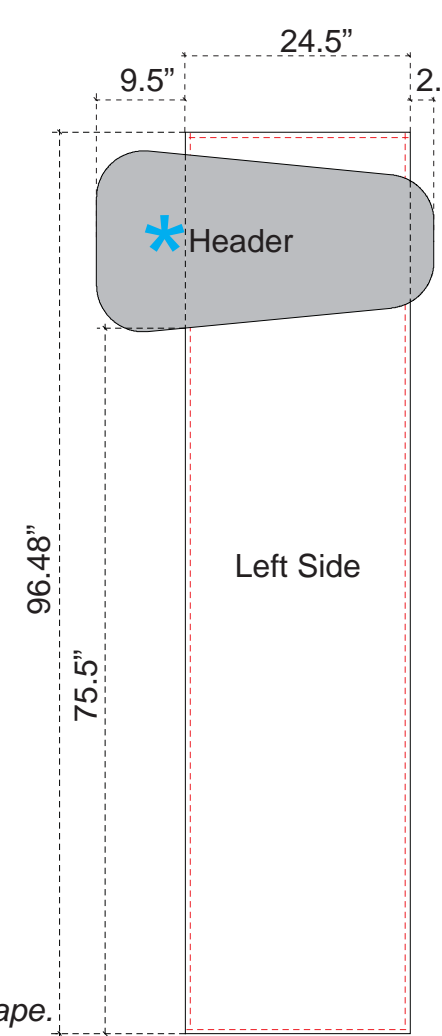
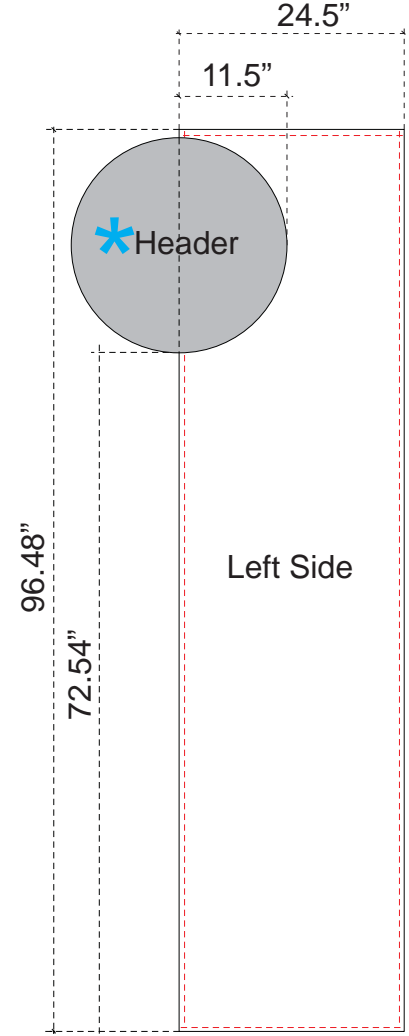
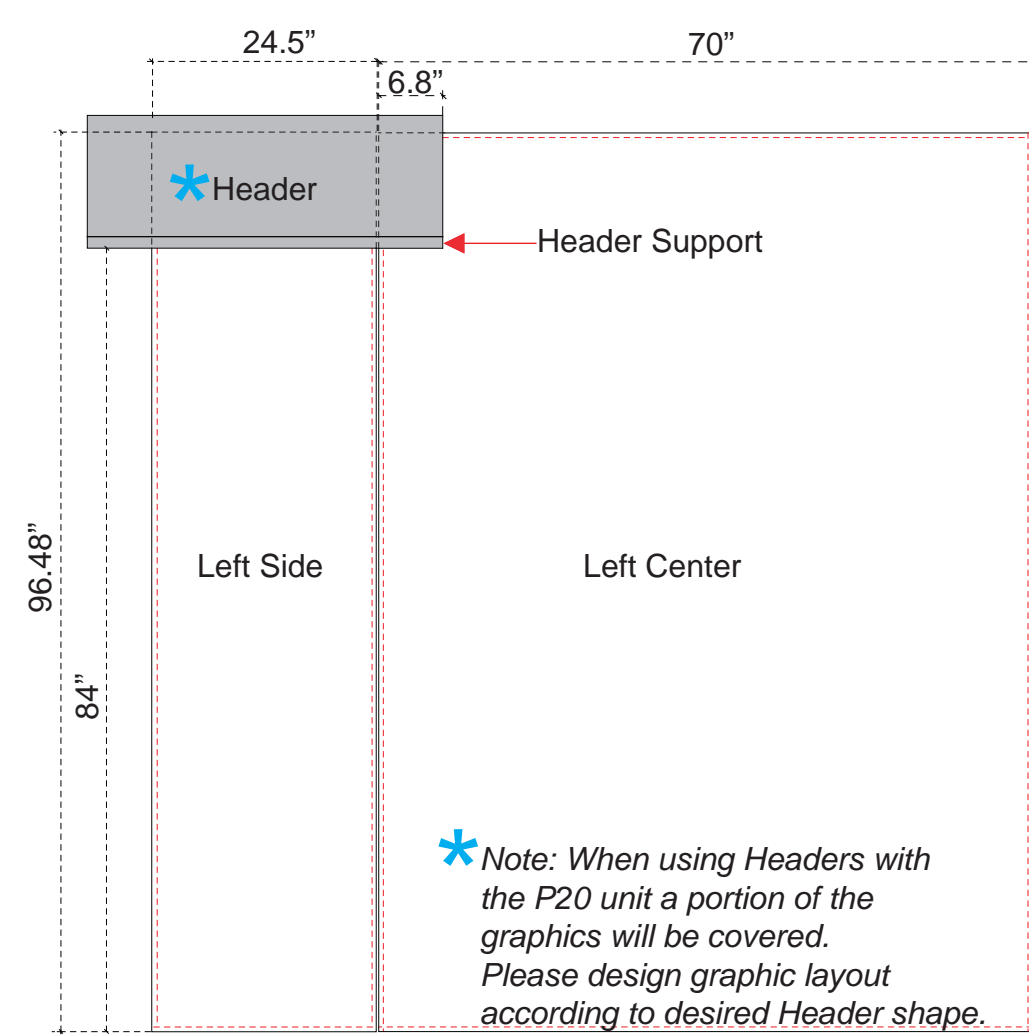

Note: Header locations will be reversed when used on the right side of the P20.

Note: Please refer to Backwall Graphic Dims page for complete instructions for Left Side fabric graphic.

Product Name: Perfect 20
Process: Print on
Material: 1/16" Sintra
Effective Date: 11/17/2009

**P20 Workstation Slide in Front Panel Graphic Dims**

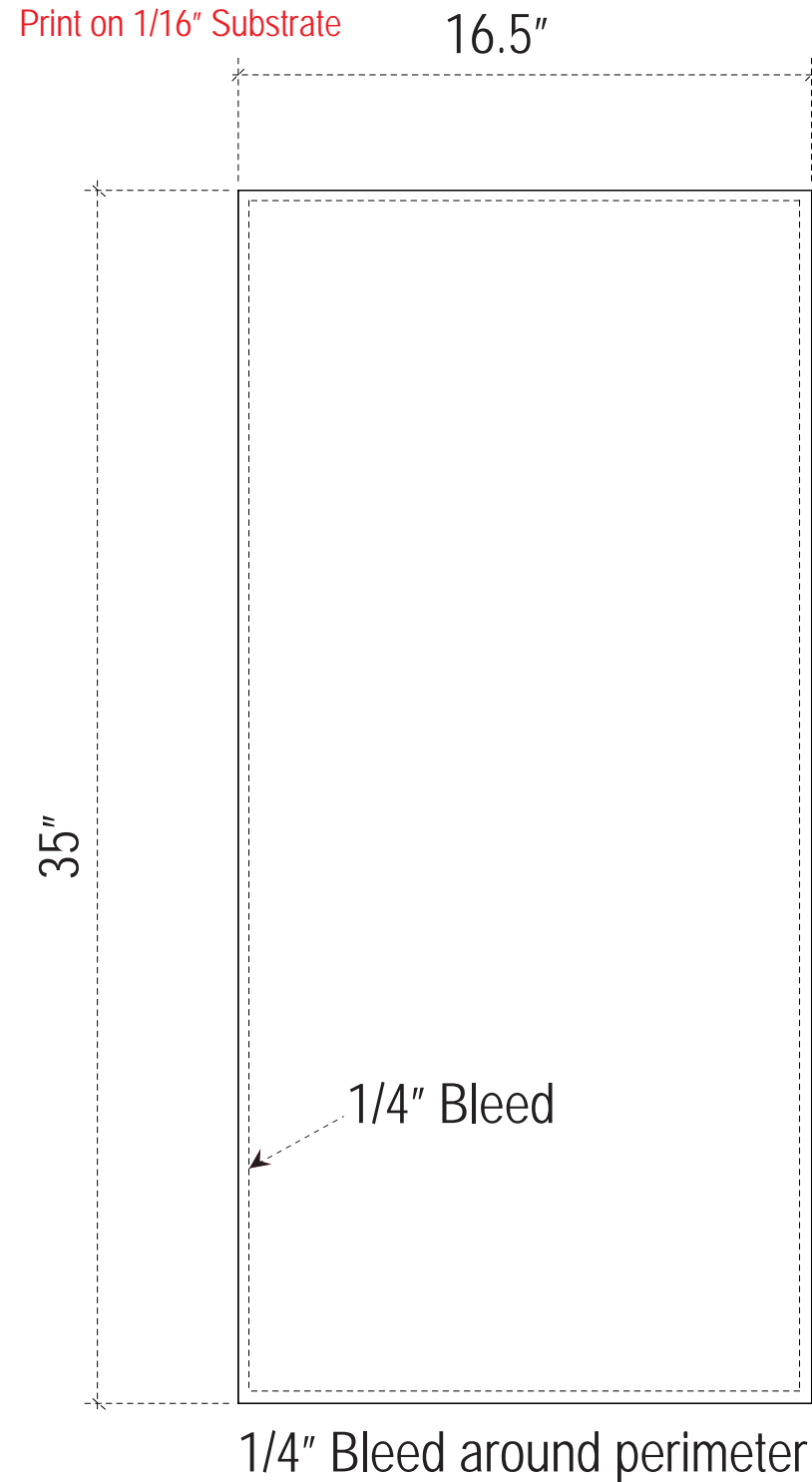

**NOTE: Graphic files must be @ 150 dpi Finished Size.**

**P20 Workstation Stand off Front Panel Graphic Dims**

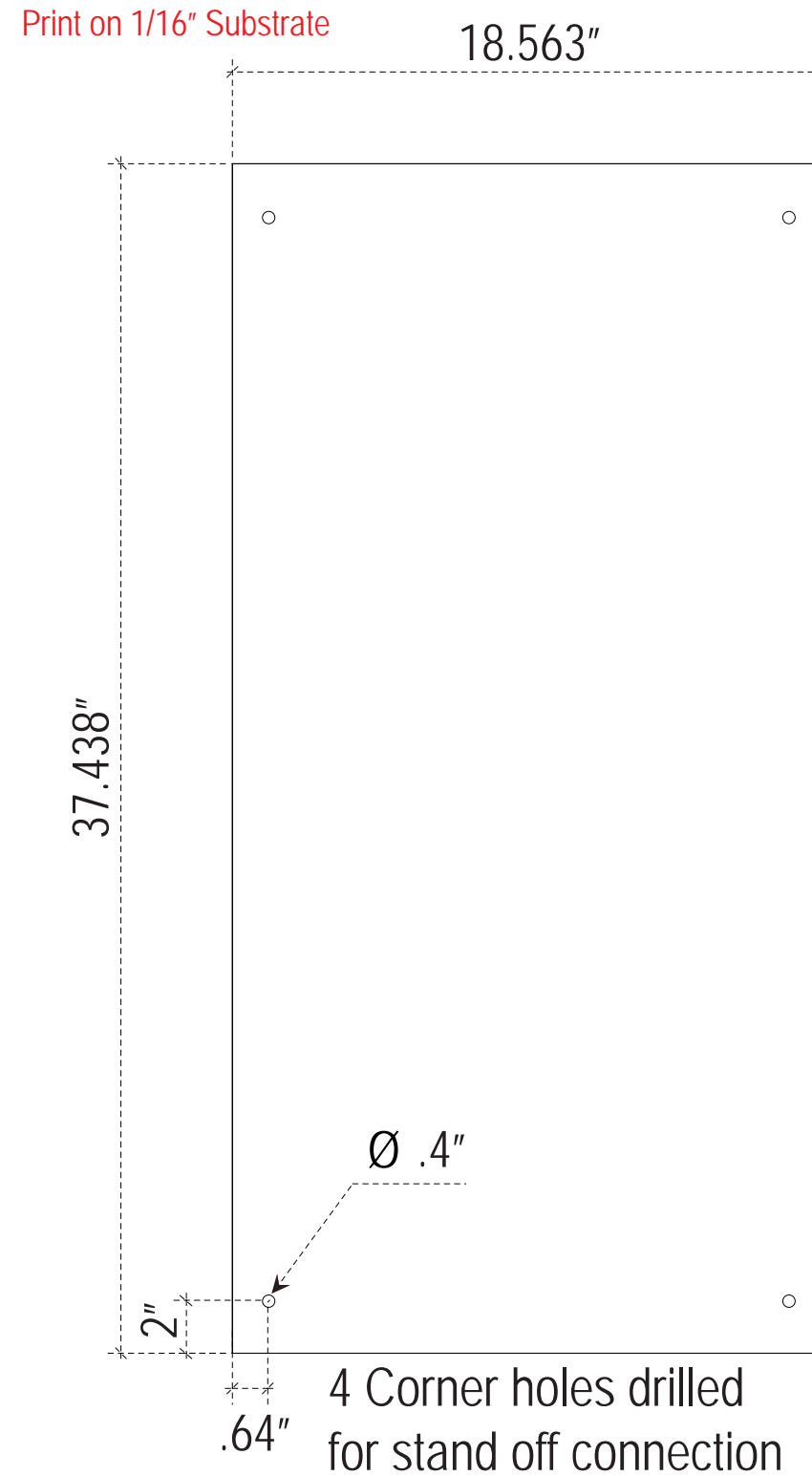

**NOTE: These dimensions are for graphic layout purposes.**